

STAR STAKE KIT ASSEMBLY INSTRUCTIONS

BE CERTAIN THAT YOU KNOW THE LOCATION OF UNDERGROUND WIRING AND UTILITIES BEFORE ATTEMPTING INSTALLATION

We highly recommend using only lightweight signs to prevent tipping of the pole over time.

- Using a block of wood to protect the stake top, drive the star stake into the ground until the notched section of the stake is flush with the ground. Use a level to check that your stake is perpendicular to the ground as you drive it in. The pole will rest on the exposed notch edge.

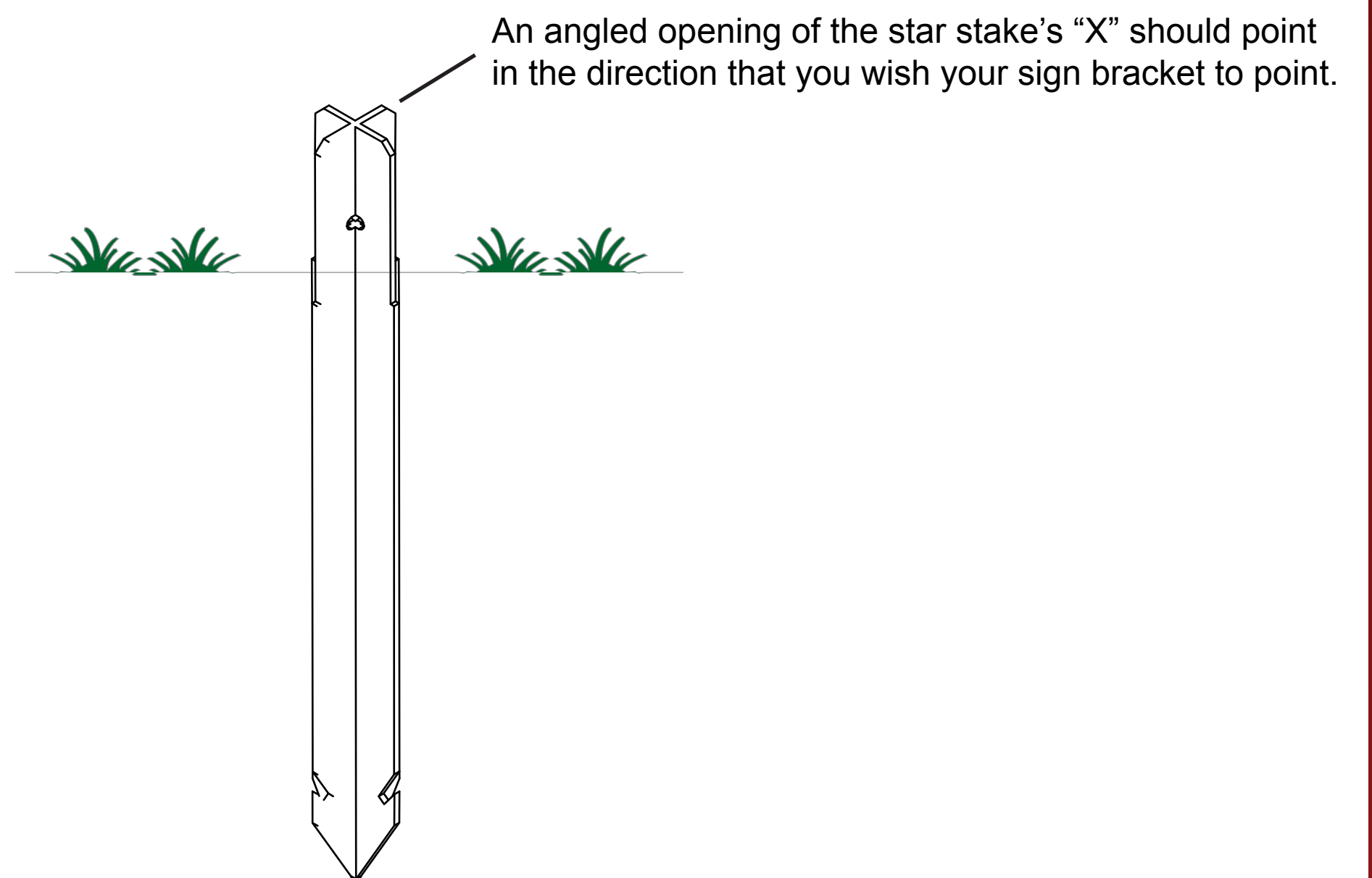

Temporarily install pole base with the base's bottom edge about 12" from bottom of pole.

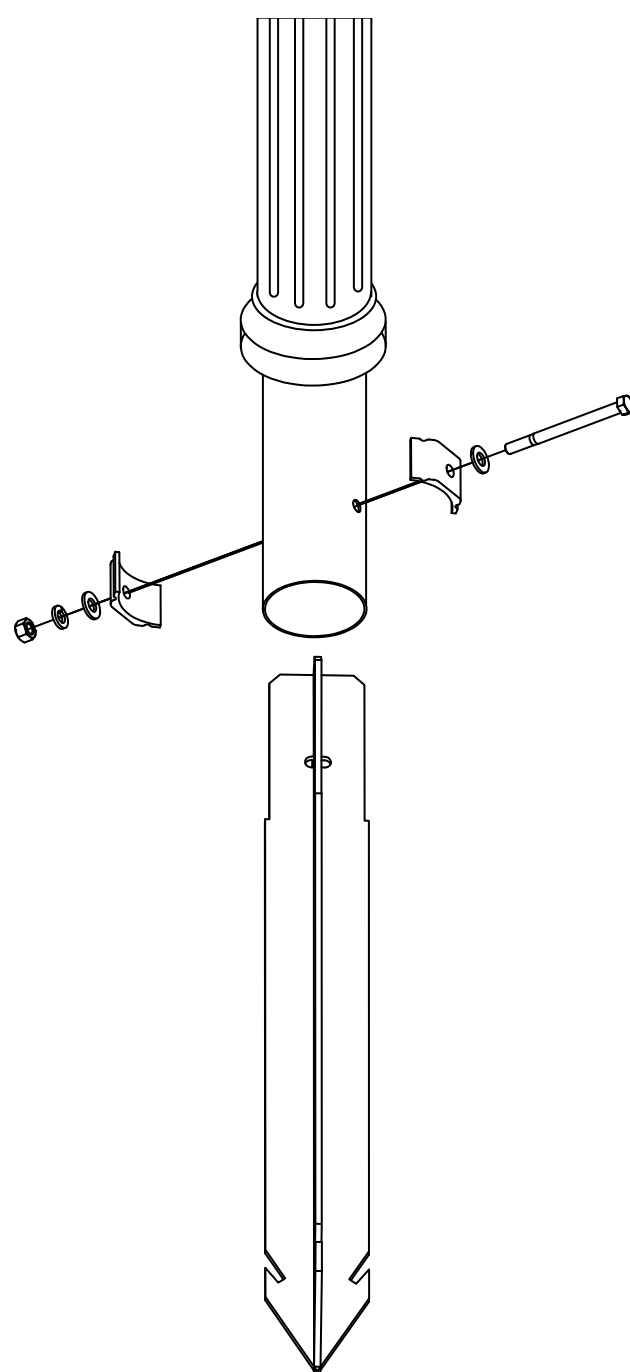

- Slide post over the star stake until it rests on the stake's notched edge. Using a bolt, (2) washers, (2) extruded washers, a lock washer and nut, attach the pole to the star stake, through the central mounting hole.

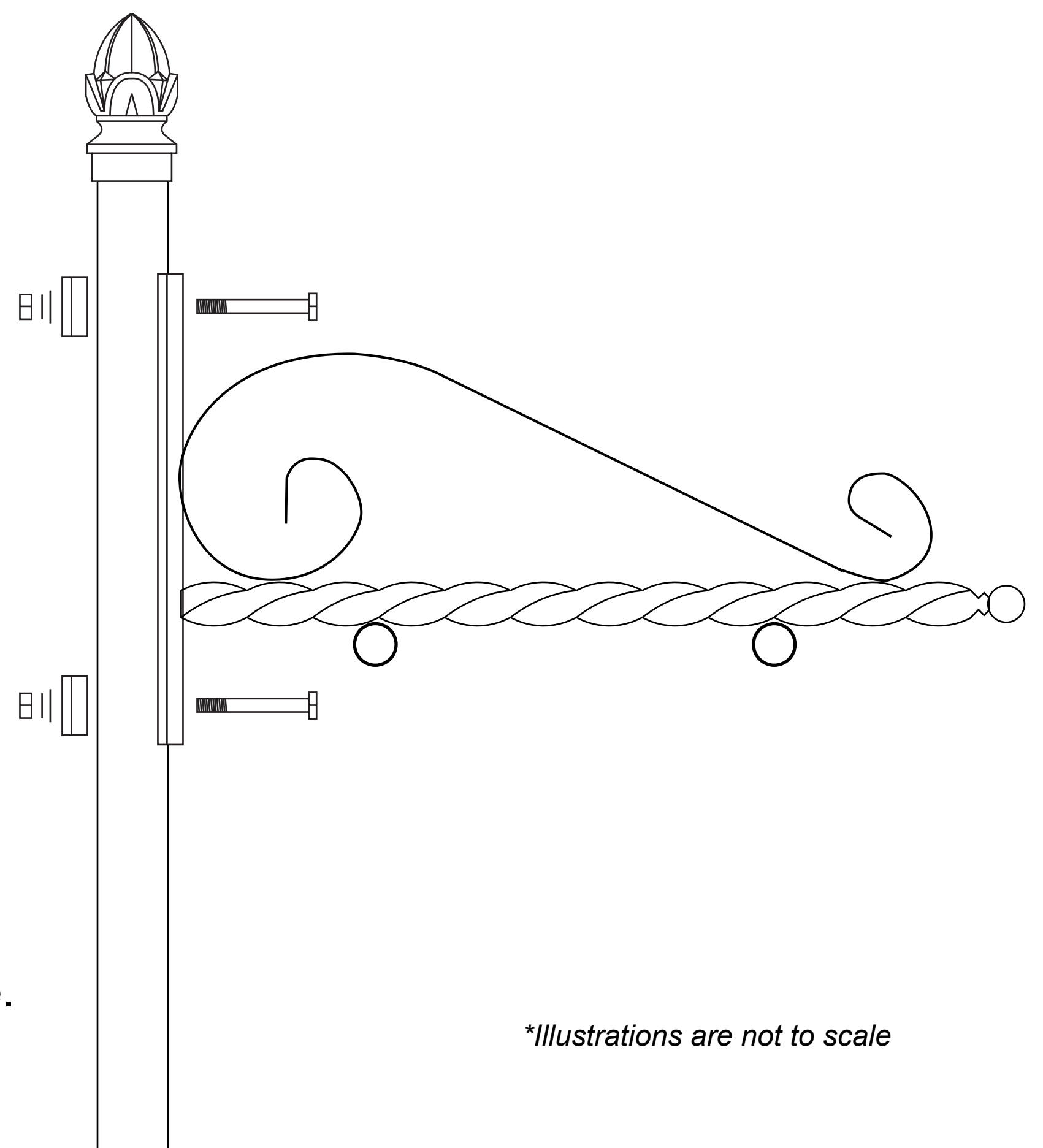

**Illustrations are not to scale*

- Install finial onto the top of the pole and tighten the set screw to hold it in position.
- Using (2) bolts, (4) washers, (2) extruded washers, (2) lock washers and (2) nuts, install the bracket onto the pole. Tighten nuts onto bolts snugly.