

FREE STANDING VINYL RACK ASSEMBLY INSTRUCTIONS

TOOLS NEEDED FOR ASSEMBLY:

1/4" Drive Socket Phillips Head Screwdriver
Shallow 1/2" Socket Hammer for Tapping Cap Plugs In
1/2" Open End Wrench Measuring Tape

PARTS LIST:

4 - 6' Loop Poles	6 - 2" Phillips Head Bolts
1 - 22.5" Tube with Cap Plugs	6 - 2" Bolts
1 - 28" Tube with Holes	4 - 2.5" Phillips Head Bolts
1 - 28" Tube without Holes	2 - 3" Bolts
1 - 30" Tube	4 - 5/16" Locking Nuts
2 - 29" Tube with Cap Plugs	8 - Cap Plugs
2 - 18.5" Tube with Cap Plugs	

Lay out parts as shown.

During assembly, leave all bolts and nuts loosely tightened until all of the parts are assembled and then tighten them.

Be careful not to stress metal.

There are (3) different lengths of bolts.

Make sure to use the proper length bolt at each connection.

Make sure the (4) phillips head bolts are on the front of the loop poles.

1. Start by laying out the (4) loop poles approximately 6-1/4" apart. All loops should be angled up. All loop poles are identical.
2. Attach the 22-1/2" tube to the top of the (4) loop poles.
3. Attach the 28" tube (with 4 holes) to the top of the loop poles. The larger holes are on the bottom.
4. Attach the 30" tube to the face of the loop poles. Make sure that the phillips head bolts are installed on the front side.
5. Attach the top of the (2) 29" tubes to the 30" tube. The end with the angle cut goes on the bottom.
6. Attach the back of the 18-1/2" tubes to the 28" tube on the base.
7. Attach the 28" tube (without the holes) by running the bolt through the bottom of the 29" tube and the front of the 18-1/2" tube.
8. Tighten all of the bolts so that the rack becomes rigid.
9. Install the plastic cap plugs by tapping them into the ends of all of the tubes except for the bottom ends (45 degree angle cut) of the 29" tubes.
10. Stand the unit up and check to ensure that it is rigid. If not, tighten any loose connections.

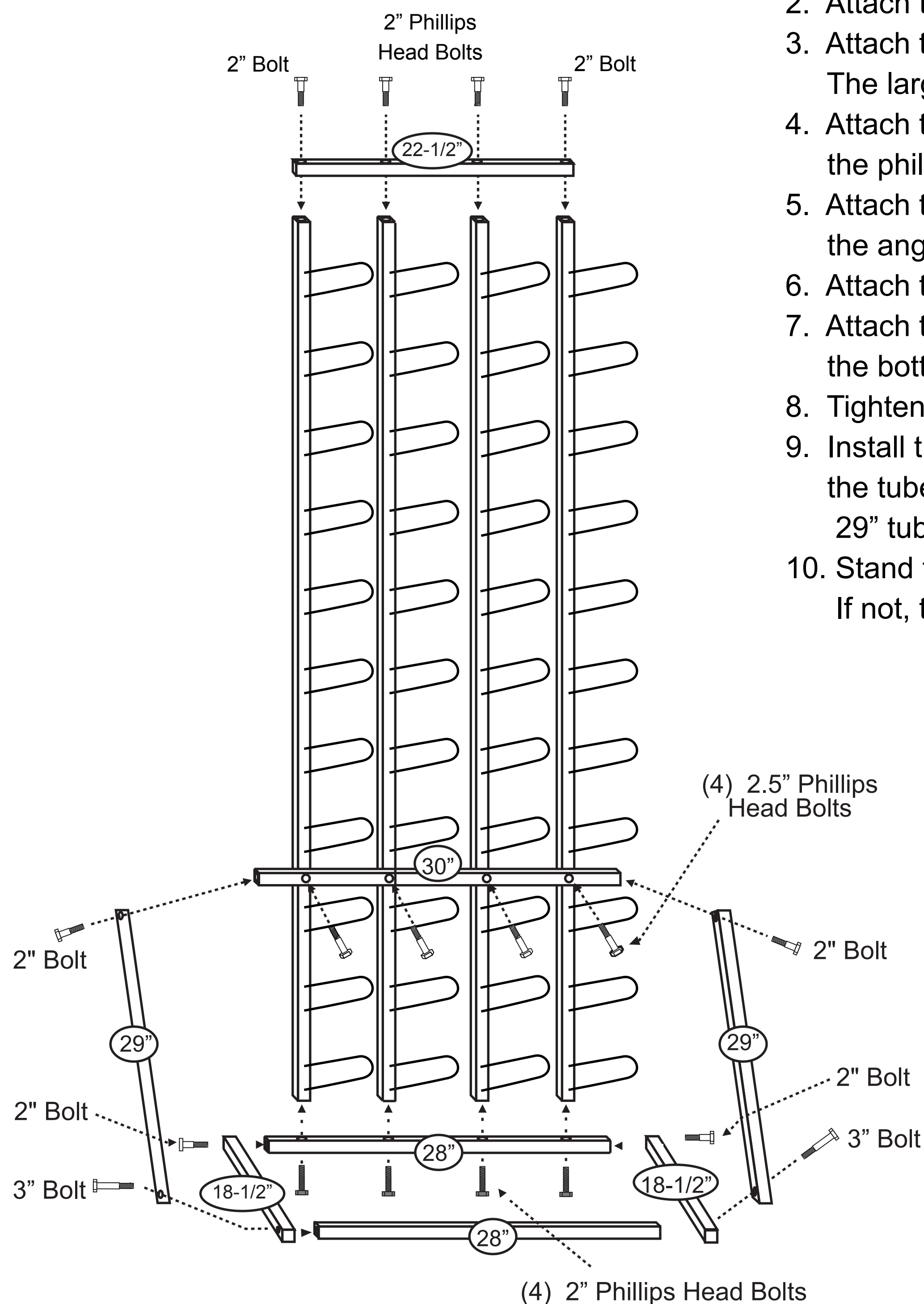

**Illustrations are not to scale*