

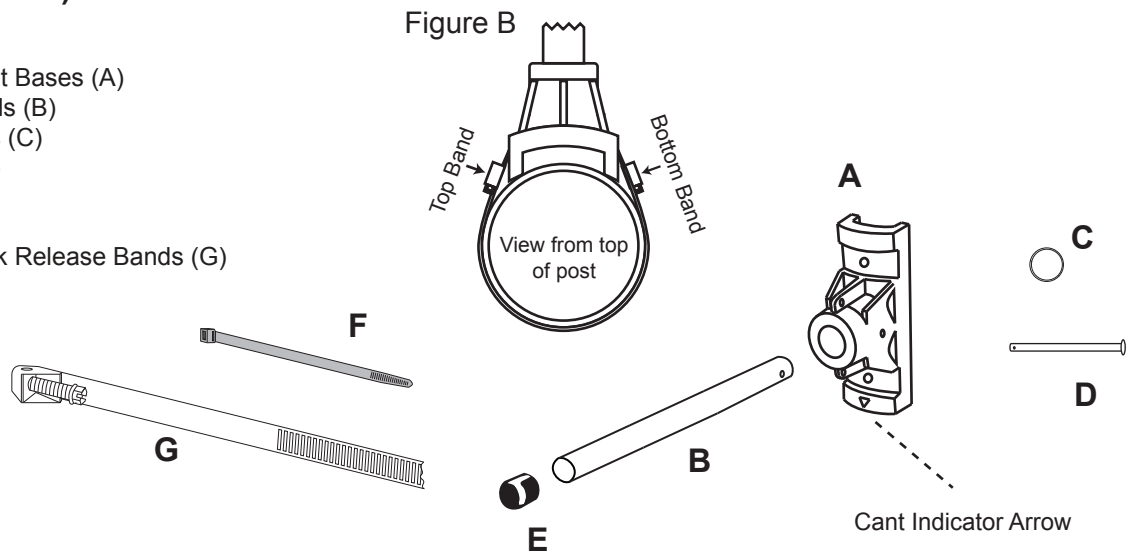

POLE MOUNT BANNER BRACKET ASSEMBLY INSTRUCTIONS (Fiberglass Rods)

PARTS LIST:

- 2 - Banner Bracket Bases (A)
- 2 - Fiberglass Rods (B)
- 2 - Retainer Rings (C)
- 2 - Clevis Pins (D)
- 2 - End Caps (E)
- 2 - Zip Ties (F)
- 4 - Stainless Quick Release Bands (G)



IMPORTANT NOTE:

Mounts have a 1 degree cant to provide tension on the banner.
Arrows stamped in mount should point away from each other.
Top bracket points up and bottom bracket points down.

**Illustrations are not to scale*

1. Position top bracket (A) onto pole with the directional arrow pointing upward and install using (2) stainless quick release bands (G). Alternate the direction of pull for each band (Figure B).
2. Insert banner rod (B) into the mount. Align the holes and secure with clevis pin (D) and attach retainer ring (C).
3. Install end cap (E) onto banner rod (B).
4. Slide banner onto top rod to aid in determining location for bottom bracket.
5. Position bottom Bracket (A) onto post with directional arrow pointing downward and install using (2) stainless quick release bands (G). Alternate the direction of pull for each band (Figure B).
6. Install banner rod (B) into bottom bracket (A), as in step 2.
7. Install end cap (E) onto banner rod (B).
8. Slide banner to outside edge of top rod and thread both top and bottom banner pockets completely onto their respective banner rods.
Note that poles may need to be flexed toward each other to relieve tension.
9. Secure inner edge of banner to the retainer ring (C) using zip tie (F).

***DO NOT USE** power tools to tighten bands - this may damage the band and will void warranty.

***Bracket mounts may be drilled** to allow use of screws or bolts to aid in securing by carefully drilling through indentations in the mounts.

***DO NOT USE** quick release bands on square posts.